

MAXIMATOR® AIR DRIVEN Liquid Pumps

MAXIMATOR® US
MAXPRO Technologies

PPO SERIES

PRESSURES FROM 60 TO 14,500 PSI

S & S-D SERIES

PRESSURES FROM 105 TO 14,500 PSI

PP SERIES

PRESSURES FROM 60 TO 60,000 PSI

L SERIES

PRESSURES FROM 165 TO 101,000 PSI

L-D SERIES

PRESSURES FROM 165 TO 38,425 PSI

GX SERIES

PRESSURES FROM 540 TO 22,500 PSI

GPD SERIES

PRESSURES FROM 450 TO 43,500 PSI

PPSF SERIES

PRESSURES FROM 60 TO 14,500 PSI

LSF SERIES

PRESSURES FROM 165 TO 23,200 PSI

MAXPRO CUSTOM DESIGNED
Power Packs, Pump Skids,
Portable Test Carts and Test Benches

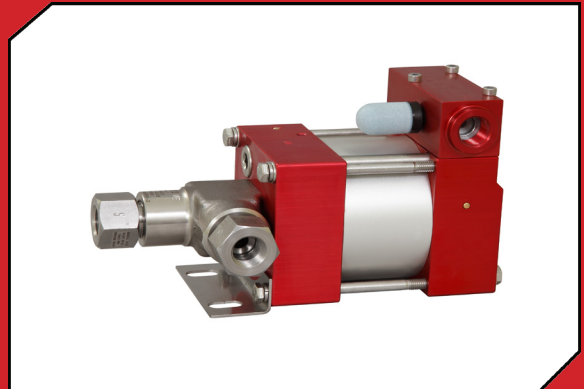

MAXIMATOR®

Liquid Pumps

AIR DRIVEN FROM 60 PSI TO 101,000 PSI

Maximator high efficiency pumps are ideal for a broad variety of oil, water, and chemical applications. They feature a large air piston joined to a smaller diameter plunger. The pressure ratio is the ratio of these two areas and is the method of determining maximum output pressure. Higher pressures are obtained by using higher pressure ratios. Maximator model numbers reflect the pump's nominal pressure ratios, while the technical data indicates exact ratios.

Maximator air driven pumps cycle automatically. The pump stops automatically when the output pressure forces and the air drive forces are equal. The pump restarts with a slight drop in the outlet pressure or an increase in the air drive pressure.

FEATURES

- **Easy to install and operate**
- **Pressure maintained without energy consumption**
- **A safe option for hazardous areas...no electrical power required**
- **Pilot air control for remote operation standard on many models**
- **External spool valve for quick maintenance on most models**
- **Dry Air Spool valve option available for severe service application**
- **Chemical service pumps are standard with separation fitting**
- **Optional seal materials, port connections, double acting, multiple air heads, single stroke, adjustable stroke, special pumps, just ask!**

HOW TO SELECT A MAXIMATOR PUMP

1. Consider the type of fluid to be pumped and compatible materials.
2. Know the available minimum plant air pressure
3. Determine the required outlet pressure.
4. Determine the required flow rate.
5. Feel free to consult your distributor or MAXPRO for application assistance.

Flow rates for each pump, at various air drive pressures and outlet pressures, are provided in the catalog. These pumps run very rapidly at no load and slow down as pressure increases. The pump will eventually come to a stop at the "stall" pressure, which is the air drive pressure times the pressure ratio of the pump. At this "stall" point there is no flow and no air consumption. The pump will hold the outlet pressure indefinitely and will only stroke if the outlet pressure drops or the air drive pressure is increased.

INSTALLATION AND MAINTENANCE

- Maximator pumps can be installed in any position, but vertical is best for longest seal life.
- All connections to the pump, both liquid (inlet and outlet) and air drive lines, must be run with equal or greater size than the connections to the pump.
- The maximum recommended height of a pump suction above the fluid level is 10 ft. for L pumps, 7 ft. for S pumps, and 3 ft. for PPO and PP pumps. Operate pump slowly during initial prime.
- Drive air should be filtered between 5 μ and 40 μ and have a maximum dewpoint of 50°F. Very wet air will wash out lubricant and cause exhaust icing. Very dry air (dew point below 0°F) will dry out lubricant and cause premature failure of spool O-rings and requires the use of the Dry Air Spool option.
- Pumped liquids should be filtered at 100 μ or better, viscosity between 1-100 cst.
- Pump performance is affected by many operating conditions. Extreme temperatures, pressures, and high duty cycles will increase maintenance frequency.
- All units are lubricated at the factory with silicone free semi-synthetic grease. After 2-3 months of normal (50% duty) operation, the standard spool seals should be inspected for wear and re-lubricated. Based on this inspection, future maintenance intervals can be planned and further disassembly and lubrication of other moving seals may be necessary. Optional Dry Air Spool seals require less maintenance.
- MAXPRO offers complete technical and service support for all Maximator pumps
Customer service is our priority!

Index

How to Select a MAXPRO Pump	2
Installation and Maintenance	2
Oil or Oil/Water Service	
PPO Series	3
S and S-D Series	4-5
Water or Oil Service	
PP Series	6-7
L Series	8-10
L-D Series	11
GX Series	12
GPD Series	13
Chemical Service	
PPSF Series	14
LSF Series	15
Portable Systems	16-17
Accessories	18-19

PPO pumps are lightweight and rugged making them ideal for portable power packs and are available in eight pressure ratios as listed below. PPO pumps are single acting, single air drive head.

- Anodized aluminum pump heads on the PPO4-PPO12, cast iron pump heads on the PPO22-PPO189. Tool steel plungers and polyurethane seals on all.
- All PPO series pumps are standard with bottom inlet. For a side inlet, add -S to the catalog number. (PPO22 and above only.)
- Maximum air drive pressure is 145 psi. PPO pumps require less drive pressure because the pump is driven in both directions with no spring under the piston.
- This design reduces noise and provides less chance of cavitation.
- Minimum air drive pressure 15 psi.
- For air control option, add -ACM to the catalog number.
- Double acting are available as a special order.

PPO

SERIES

PRESSURES FROM
60 TO 14,500 PSI

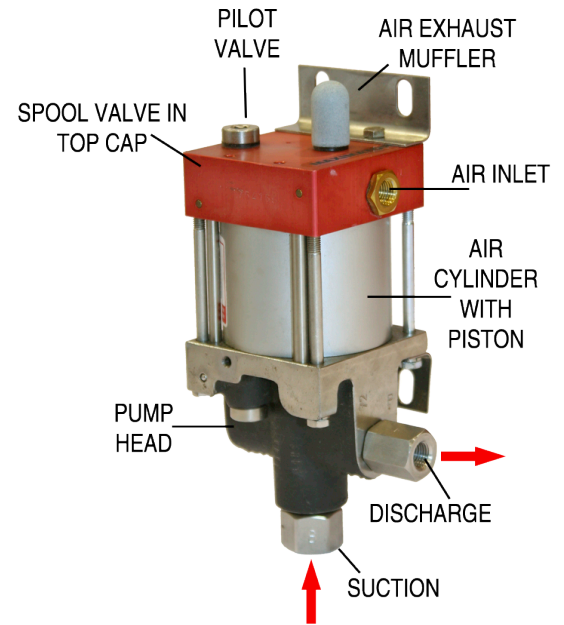

TECHNICAL DATA

CATALOG NUMBER	PRESSURE RATIO	MAXIMUM OUTLET PRESSURE (PSI)	DISPL. PER CYCLE (IN. ³)	CONNECTIONS (FNPT - IN.)		WEIGHT (LBS.)
				INLET	OUTLET	
PPO4	1:4	580	1.86	1	1/2	6
PPO8	1:9	1,305	0.90	3/4	1/2	
PPO12	1:14	2,030	0.57	3/4	1/4	
PPO22	1:29	4,205	0.28	3/8	1/4	7
PPO37	1:47	6,815	0.17	3/8	1/4	
PPO72	1:88	12,760	0.09	3/8	1/4	
PPO111	1:133	14,500	0.06	3/8	1/4	
PPO189	1:225	14,500	0.04	3/8	1/4	

NOTE: Air drive inlet connection on all PPO pumps is 1/4" FNPT.
Maximum allowable oil temperature is 140°F.
Air section temperature rating: 0°F to 140°F.

See page 7 PP Pump Flow Page for PPO Flow Chart

DIMENSIONS (inches) - PPO4 - PPO12

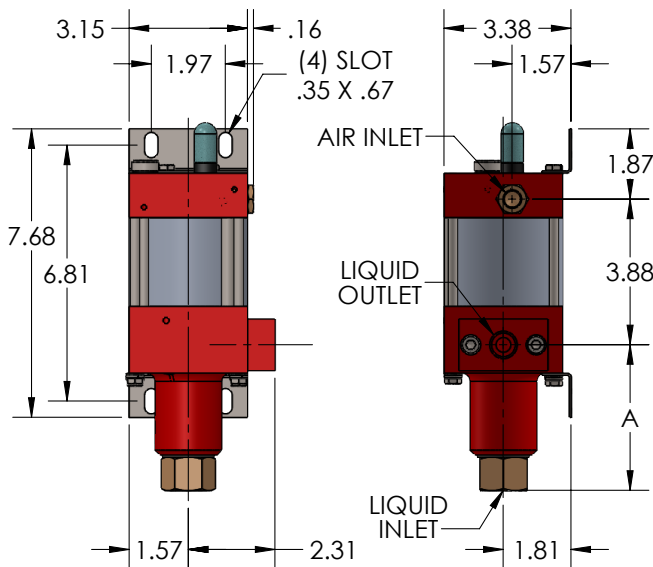

CATALOG NUMBER	A
PPO4	4.44
PPO8, PPO12	3.88

DIMENSIONS (inches) - PPO22 - PPO189

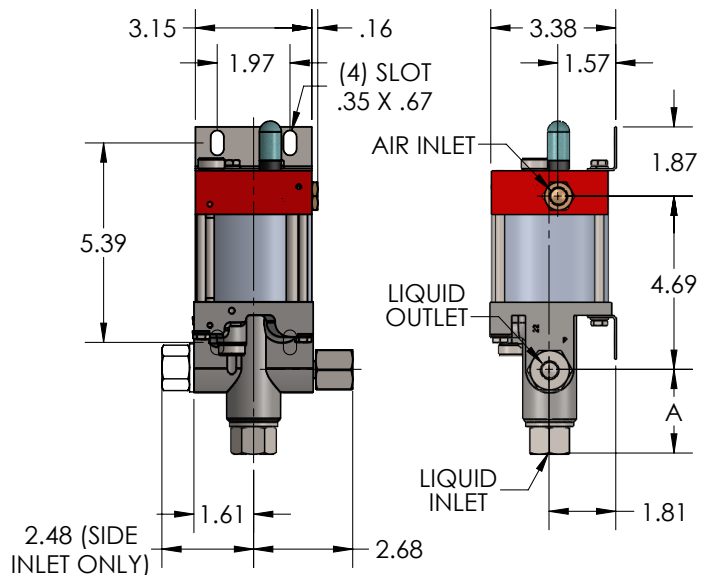

CATALOG NUMBER	A	
	BOTTOM INLET	SIDE INLET
PP22-PP189	2.26	.66

OIL or OIL/WATER SERVICE

S

SERIES

PRESSURES FROM
105 TO 14,500 PSI

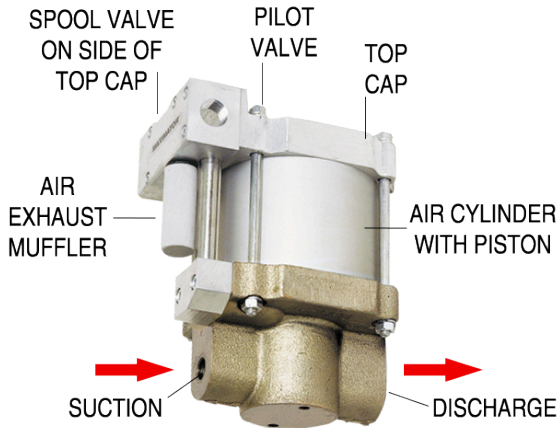

S pumps are compact and lightweight and are designed for simple installation in both static and portable applications. Available in six pressure ratios, S pumps are ideal for applications demanding fast response times.

- S pumps are single acting, single air drive head types.
- Cast iron pump heads, carbon steel plungers and polyurethane seals.
- All S pumps are standard with side inlet only.
- Maximum air drive pressure is 145 psi.
- Minimum air drive pressure 15 psi.
- For air control option, add -AC to the catalog number.
- No pilot port. Internally piloted.

TECHNICAL DATA S PUMPS

CATALOG NUMBER	PRESSURE RATIO	MAXIMUM OUTLET PRESSURE (PSI)	DISPL. PER CYCLE (IN. ³)	CONNECTIONS (FNPT - IN.)		WEIGHT (LBS.)
				INLET	OUTLET	
S15	1:17	2,465	1.73	3/4	1/2	20
S25	1:25	3,625	1.20	1/2	1/2	
S35	1:39	5,655	0.77	1/2	1/2	
S60	1:61	8,845	0.49	1/2	1/2	
S100	1:108	14,500	0.27	1/2	1/2	
S150	1:156	14,500	0.19	1/2	1/2	

S-D pumps are compact and lightweight and are designed for simple installation in both static and portable applications. Available in six pressure ratios, S-D pumps are ideal for high flow applications. The S-D pumps are the double acting version of the S pumps.

- S-D pumps are double acting, single air drive head types.
- Cast iron pump heads, carbon steel plungers and polyurethane seals.
- All S-D pumps are standard with side inlets only.
- There are two inlets (same side) and two outlets (same side).
- Maximum air drive pressure is 145 psi.
- Minimum air drive pressure 15 psi.
- For air control option, add -ACP to the catalog number.
- All S-D pumps come with an unregulated pilot port, 1/8" FNPT, in the top cap. This feature provides more accurate pressure control and is an ideal location for control instrumentation.

TECHNICAL DATA S-D PUMPS

CATALOG NUMBER	PRESSURE RATIO	MAXIMUM OUTLET PRESSURE (PSI)	DISPL. PER CYCLE (IN. ³)	CONNECTIONS (FNPT - IN.)		WEIGHT (LBS.)
				INLET	OUTLET	
S15-D	1:16	2,320	3.48	3/4	1/2	32
S25-D	1:24	3,480	2.39	1/2	1/2	
S35-D	1:38	5,510	1.54	1/2	1/2	
S60-D	1:60	8,700	0.98	1/2	1/2	
S100-D	1:107	14,500	0.55	1/2	1/2	
S150-D	1:155	14,500	0.38	1/2	1/2	

NOTE: Air drive inlet connection on all S and S-D pumps is 1/2" FNPT.
Maximum allowable oil temperature is 140°F.
Air section temperature rating: 0°F to 140°F.

S-D

SERIES

PRESSURES FROM
105 TO 14,500 PSI

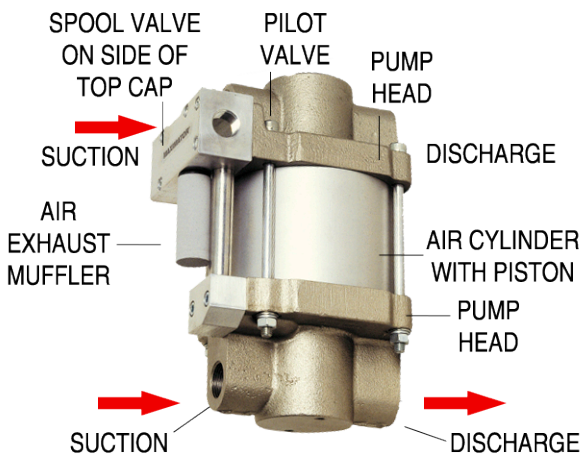

FLOW CHART - S SERIES

CATALOG NUMBER	SAMPLE AIR DRIVE PRESSURE (PSI)	OUTLET PRESSURE (PSI)									
		0	500	1000	1500	2000	3000	4000	5000	7500	10000
S15	60	555	380	25							
	90	575	480	310	60						
S25	60	400	330	175							
	90	410	370	305	205	80					
S35	60	255	230	185	125	50					
	90	265	250	228	200	165	65				
S60	60	162	153	138	120	90	35				
	90	168	163	156	147	137	108	71	25		
S100	60	92	89	86	82	76	60	43	26		
	90	95	94	92	89	87	82	73	63	36	
S150	60	62	61	60	59	56	53	47	42	20	
	90	65	64	63	62	61	60	57	53	42	27

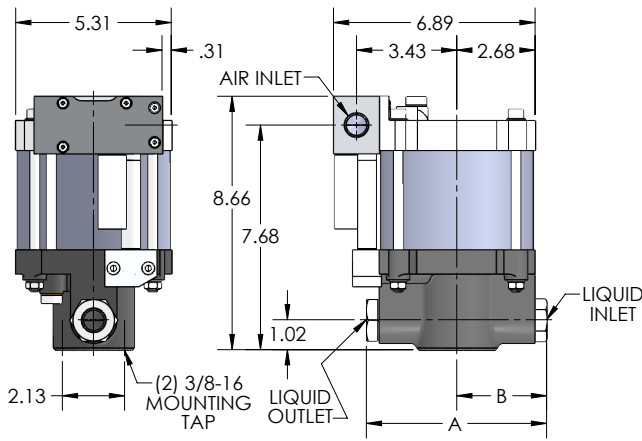

CATALOG NUMBER	A	B
S15	6.63	3.69
S25, S35	6.06	3.00
S60, S100	7.81	4.06
S150	7.81	3.88

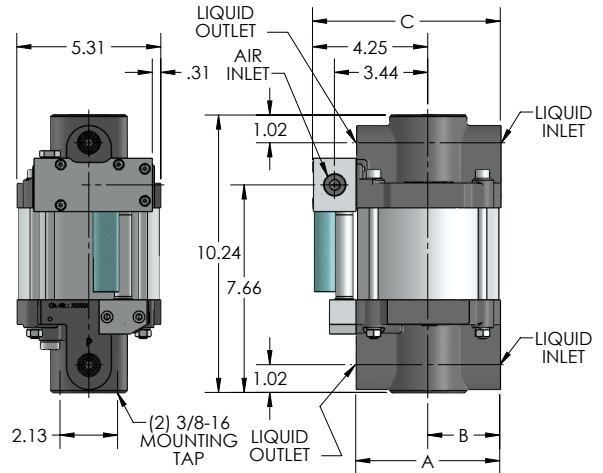

CATALOG NUMBER	A	B	C
S15-D	6.63	3.69	7.88
S25-D, S35-D	6.06	3.00	7.19
S60-D, S100-D, S250-D	7.81	4.06	8.25

FLOW CHART - S-D SERIES

CATALOG NUMBER	SAMPLE AIR DRIVE PRESSURE (PSI)	OUTLET PRESSURE (PSI)									
		0	500	1000	1500	2000	3000	4000	5000	7500	10000
S15-D	60	1050	650								
	90	1075	900	520							
S25-D	60	715	575	280							
	90	730	660	530	340	90					
S35-D	60	455	405	315	205	75					
	90	465	440	400	345	280	90				
S60-D	60	285	270	240	210	160	60				
	90	290	285	270	265	235	185	120	40		
S100-D	60	160	153	147	141	130	110	80	50		
	90	165	163	157	154	150	140	126	111	60	
S150-D	60	110	105	105	102	100	90	80	70	35	
	90	120	115	115	110	107	100	95	90	70	45

FLOW RATE IN CUBIC INCHES PER MINUTE.
MAXIMUM AIR CONSUMPTION: 33 SCFM @ 90 PSI (WITH 0 PSI OUTLET).

FLOW RATES SHOWN ARE FOR 1-10 CST FLUIDS.

WATER or OIL SERVICE

PP

SERIES

PRESSURES FROM
60 TO 60,000 PSI

PP pumps are compact and lightweight and feature rugged construction. They are available as single acting with either single, double, or triple air drive heads and double acting with single air drive head.

- PP4 through PP12 pumps have anodized aluminum pump heads and stainless steel plungers. PP22 through PP189 have stainless steel pump heads and plungers. All PP pumps have polyurethane seals with Buna-N O-rings standard.
- All PP series pumps are standard with a bottom inlet. For a side inlet, add -S to the catalog number. For a hand lever, add -HL (PP22 and above only).
- Air drive pressure range is 15 - 145 psi.
- For air control option, add -ACM to the catalog number.
- With the hand lever option, the pump can operate with air or hand lever.
- Multiple air heads increase the effective pressure ratio of the pump. This provides higher pressure capabilities using less air pressure to achieve a given outlet pressure.

TECHNICAL DATA

Single Air Drive Head

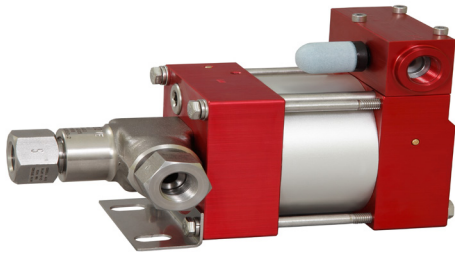

CATALOG NUMBER	PRESSURE RATIO	MAXIMUM OUTLET PRESSURE (PSI)	DISPL. PER CYCLE (IN. ³)	CONNECTIONS (FNPT - IN.)		WEIGHT (LBS.)
				INLET	OUTLET	
PP4	1:4	580	1.86	1	1/2	7
PP8	1:9	1,305	0.90	3/4	1/2	
PP12	1:14	2,030	0.57	3/4	1/2	
PP22	1:28	4,060	0.28	3/8	1/4	
PP37	1:46	6,670	0.17	3/8	1/4	
PP72	1:86	12,470	0.09	3/8	1/4	
PP111	1:130	15,000	0.06	3/8	1/4	
PP189	1:220	31,900	0.04	3/8	1/4 HP	

Single Air Drive Head with Hand Lever

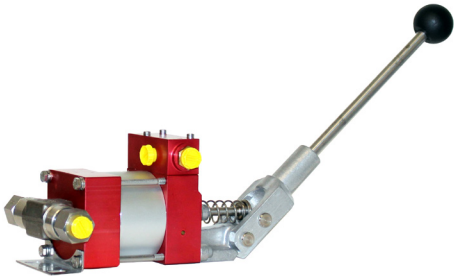

CATALOG NUMBER	PRESSURE RATIO	MAXIMUM OUTLET PRESSURE (PSI)	DISPL. PER CYCLE (IN. ³)	CONNECTIONS (FNPT - IN.)		WEIGHT (LBS.)
				INLET	OUTLET	
PP22-HL	1:28	4,060	0.28	3/8	1/4	9
PP37-HL	1:46	6,670	0.17	3/8	1/4	
PP72-HL	1:86	12,470	0.09	3/8	1/4	
PP111-HL	1:130	15,000	0.06	3/8	1/4	
PP189-HL	1:220	31,900	0.04	3/8	1/4 HP	

Double Air Drive Head

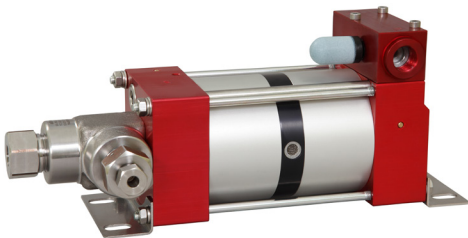

CATALOG NUMBER	PRESSURE RATIO	MAXIMUM OUTLET PRESSURE (PSI)	DISPL. PER CYCLE (IN. ³)	CONNECTIONS (FNPT - IN.)		WEIGHT (LBS.)
				INLET	OUTLET	
PP111-2	1:261	36,250	0.06	3/8"	1/4 HP	9
PP189-2	1:440	60,000	0.04	3/8"	1/4 HP	

Triple Air Drive Head



CATALOG NUMBER	PRESSURE RATIO	MAXIMUM OUTLET PRESSURE (PSI)	DISPL. PER CYCLE (IN. ³)	CONNECTIONS (FNPT - IN.)		WEIGHT (LBS.)
				INLET	OUTLET	
PP111-3	1:391	36,250	0.06	3/8"	1/4 HP	9
PP189-3	1:660	60,000	0.04	3/8"	1/4 HP	

NOTE: Air drive inlet connection on all PP pumps is 1/4" FNPT. All connections listed are FNPT unless otherwise noted. Maximum allowable oil temperature is 140°F. Air section temperature rating: 0°F to 140°F.

FLOW CHART - PP SERIES

CATALOG NUMBER	SAMPLE AIR DRIVE PRESSURE (PSI)	OUTLET PRESSURE (PSI)										
		0	500	1500	3000	5000	7500	10000	15000	25000	40000	55000
PP4	60	885										
	90	905										
PP8	60	422	50									
	90	430	240									
PP12	60	272	160									
	90	275	218									
PP22	60	132	110	22						Above 35,000 psi for intermittent duty only		
	90	136	126	82								
PP37	60	81	74	47								
	90	83	80	68	37							
PP72	60	43	42	37	22	3						
	90	44	43	41	36	24	3					
PP111	60	28	27	26	20	12	2					
	90	29	28	27	26	22	16	8				
PP189	60	17	15	14	13	12	9	5				
	90	17	17	17	16	15	12	11	6			
PP111-2	60	21	20	20	20	19	16	15	9			
	90	21	21	20	20	19	17	16	12			
PP189-2	60	12	12	12	11	11	10	10	7	1		
	90	12	12	12	12	12	11	11	10	7		
PP111-3	60	18	18	18	17	17	15	14	10			
	90	19	19	19	18	18	16	16	14	8		
PP189-3	60	11	11	11	10	10	10	9	9	6		
	90	11	11	11	11	11	11	10	10	8	5	

FLOW RATE IN CUBIC INCHES PER MINUTE.

MAXIMUM AIR CONSUMPTION FOR "PP" pumps: 20 SCFM @ 90 PSI (WITH 0 PSI OUTLET).

MAXIMUM AIR CONSUMPTION FOR "PP-2" pumps: 30 SCFM @ 90 PSI (WITH 0 PSI OUTLET).

MAXIMUM AIR CONSUMPTION FOR "PP-3" pumps: 35 SCFM @ 90 PSI (WITH 0 PSI OUTLET).

FLOW RATES SHOWN ARE FOR 1-10 CST FLUIDS.

**PP4, PP8, PP12
DIMENSIONS (inches)**

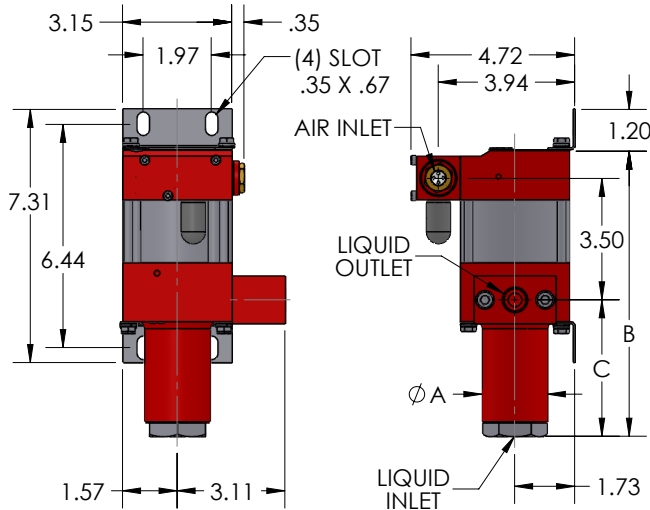

CATALOG NUMBER	A	B	C
PP4	2.13	8.50	4.22
PP8	1.88	8.25	3.94
PP12	1.88	8.25	3.94

**PP22-189
DIMENSIONS (inches)**

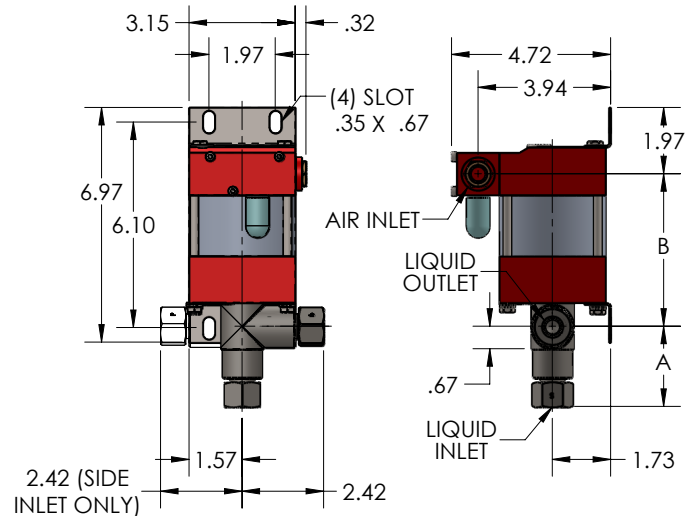

CATALOG NUMBER	A		B
	BOTTOM INLET	SIDE INLET	
PP22-PP189	2.38	.71	4.53
PP111-2, PP189-2	2.38	.71	6.93
PP111-3, PP189-3	2.38	.71	9.33

WATER OR OIL SERVICE

SERIES

PRESSURES FROM
165 to 101,000 PSI

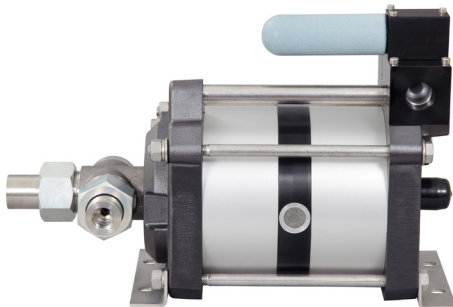
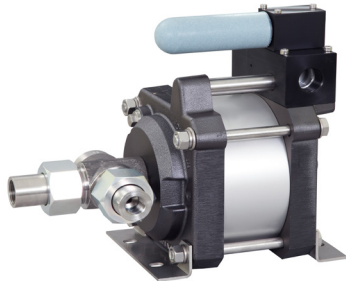
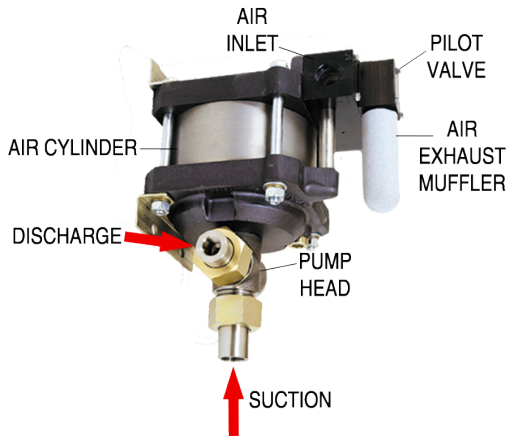

L pumps are available as single acting pumps with either a single or double air drive head and double acting with single air drive head (See L-D).

- L pumps have stainless steel pump heads and 17-4 plungers.
- All L pumps have UHMWPE (Ultra High Molecular Weight Polyethylene) seals and Viton² O-rings (-VE), except as noted.
- L pumps come standard with bottom or side inlet. For a side inlet, add -S to the catalog number.
- Air drive pressure range is 15-145 psi unless limited by outlet pressure.
- Air drive inlet is 1/2" FNPT.
- For air control option, add -ACP to the catalog number.
- All L pumps come with an unregulated pilot port, 1/8" FNPT, in the top cap. This feature provides more accurate pressure control and is an ideal location for control instrumentation.
- All L pumps are available with a double air drive head. This doubles the pressure ratio of the pump, allowing the use of a lower ratio base pump, to provide higher flow rates. It is also used to achieve a given outlet pressure with less air drive pressure.

TECHNICAL DATA

Single Air Drive Head

CATALOG NUMBER	PRESSURE RATIO	MAXIMUM OUTLET PRESSURE (PSI)	DISPL. PER CYCLE (IN. ³)	CONNECTIONS (FNPT - IN.)		WEIGHT (LBS.)
				INLET	OUTLET ¹	
L10-VE	1:11	1,595	5.49	1	1/2	36
L15-VE	1:16	2,320	3.78	1	1/2	
L25-VE	1:28	4,060	2.15	1/2	1/2	32
L35-VE	1:40	5,800	1.49	1/2	1/2	
L60-VE	1:63	9,135	0.94	1/2	1/2	30
L100-VE	1:113	15,000	0.54	1/2	1/2	
L150-VE	1:151	21,025	0.40	1/2	1/4 HP	
L250-VE*	1:265	38,425	0.23	1/2	1/4 HP	
L300-VE*	1:314	45,530	0.20	1/2	1/4 HP	
L400-VE*	1:398	57,710	0.15	1/2	1/4 HP	
L500-S	1:519	65,250	0.12	1/2	1/4 HP	

Double Air Drive Head

CATALOG NUMBER	PRESSURE RATIO	MAXIMUM OUTLET PRESSURE (PSI)	DISPL. PER CYCLE (IN. ³)	CONNECTIONS (FNPT - IN.)		WEIGHT (LBS.)
				INLET	OUTLET ¹	
L10-2-VE	1:22	3,190	5.49	1	1/2	46
L15-2-VE	1:32	4,640	3.78	1	1/2	
L25-2-VE	1:56	8,120	2.15	1/2	1/2	42
L35-2-VE	1:80	11,600	1.49	1/2	1/2	
L60-2-VE	1:126	15,000	0.94	1/2	1/2	40
L100-2-VE*	1:226	30,450	0.54	1/2	1/4 HP	
L150-2-VE*	1:300	42,050	0.40	1/2	1/4 HP	
L250-2-VE*	1:530	60,000	0.23	1/2	1/4 HP	
L300-2-VE*	1:628	60,000	0.20	1/2	1/4 HP	49
L400-2-VE*	1:796	60,000	0.15	1/2	1/4 HP	
L400-2S-5U	1:796	79,750	0.15	1/2	5/16 UHP	

NOTE: L500 pumps have polyurethane seals and Buna-N O-rings and are available side inlet only.
¹These pumps have UHMWPE seals and Buna-N O-rings.
 Maximum allowable oil/water temperature is 140°F.
 Air section temperature rating: 0°F to 140°F.
²Viton is a registered trademark of E.I. DuPont de Nemours & Co., Inc.

FLOW CHART - L SERIES

CATALOG NUMBER	SAMPLE AIR DRIVE PRES-SURE (PSI)	OUTLET PRESSURE (PSI)										
		0	500	1500	3000	5000	7500	10000	15000	25000	40000	55000
L10-VE	60	1100	350									
	90	1125	790									
	120	1150	915									
L15-VE	60	775	540									
	90	790	650									
	120	800	705	280								
L25-VE	60	435	365	60								
	90	445	410	265								
	120	450	425	340	90							
L35-VE	60	300	270	150								
	90	305	290	240	95							
	120	310	300	270	180							
L60-VE	60	192	182	145	45							
	90	195	190	173	130	43						
	120	200	195	185	158	105	10					
L100-VE	60	108	105	97	78	37						Above 35,000 psi for intermittent duty only
	90	110	108	105	95	78	47	5				
	120	113	110	107	103	92	73	48				
L150-VE	60	81	79	76	66	49	19					
	90	83	82	80	75	67	53	35				
	120	84	83	82	78	73	66	55	25			
L250-VE	60	46	45	44	42	37	26	20	2			
	90	47	46	45	44	43	40	36	26			
	120	48	47	47	46	45	43	41	34	17		
L300-VE	60	39	38	37	36	33	29	23	10			
	90	40	39	38	38	37	35	32	26	8		
	120	41	40	39	38	38	37	36	32	21		
L400-VE	60	30	29	29	28	27	26	23	15			
	90	31	31	31	30	30	29	27	24	15		
	120	32	32	31	31	31	30	29	27	22	8	
L500-S	60	23	23	22	21	21	20	19	16	8		
	90	24	24	23	23	23	22	22	20	15	6	
	120	24	24	24	23	23	23	23	22	19	13	5
L10-2-VE	60	880	720									
	90	890	800	350								
	120	900	840	570								
L15-2-VE	60	615	550	200								
	90	625	575	410								
	120	630	600	500	225							
L25-2-VE	60	345	330	265	60							
	90	350	335	300	208	15						
	120	355	345	320	265	150						
L35-2-VE	60	240	230	210	115							
	90	242	232	225	190	115						
	120	245	235	230	210	170	95					
L60-2-VE	60	150	148	145	120	70	2					
	90	155	152	147	136	117	80	33				
	120	157	154	152	145	133	112	82	8			
L100-2-VE	60	86	84	82	77	72	53	30				
	90	87	86	84	82	78	70	61	36			
	120	89	88	86	84	82	77	72	57	13		
L150-2-VE	60	64	64	63	60	57	50	38	14			
	90	65	65	64	62	60	57	53	41	9		
	120	66	66	65	64	63	61	58	51	32		
L250-2-VE	60	37	36	36	35	35	34	32	27	12		
	90	37	36	36	36	36	35	34	31	25	10	
	120	37	37	36	36	36	36	35	34	30	21	9
L300-2-VE	60	31	31	30	30	29	29	28	26	16		
	90	31	31	31	30	30	30	29	27	23	14	2
	120	31	31	31	31	30	30	30	29	27	21	14
L400-2-VE	60	24	24	23	23	23	22	22	21	14	5	
	90	24	24	24	24	24	23	23	23	20	15	10
	120	25	25	25	24	24	24	23	23	22	19	16

FLOW RATE IN CUBIC INCHES PER MINUTE.

MAXIMUM AIR CONSUMPTION FOR "L" pumps: 45 SCFM @ 90 PSI (WITH 0 PSI OUTLET).

MAXIMUM AIR CONSUMPTION FOR "L-2" pumps: 80 SCFM @ 90 PSI (WITH 0 PSI OUTLET).

FLOW RATES SHOWN ARE FOR 1-10 CST FLUIDS.

WATER OR OIL SERVICE

L SERIES

PRESSURES FROM
165 to 101,000 PSI

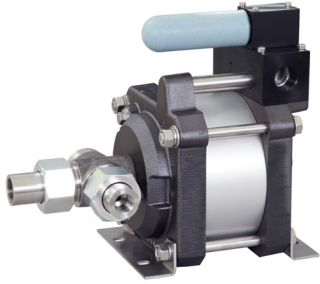

DIMENSIONS (inches) Single Air Drive Head

CATALOG NUMBER	A	AS	B	C	D	E	F
L10-VE L15-VE	12.19	--	8.25	5.06	6.88	7.81	--
L25-VE L35-VE	11.62	9.75	8.25	3.63	6.88	7.81	3.19
L60-VE L100-VE L150-VE	12.13	10.19	8.38	3.44	6.88	7.81	3.81
L250-VE L300-VE L400-VE	11.81	10.25	8.38	4.00	6.88	7.81	3.31
L500-S	15.69	--	12.38	4.00	6.88	7.81	--

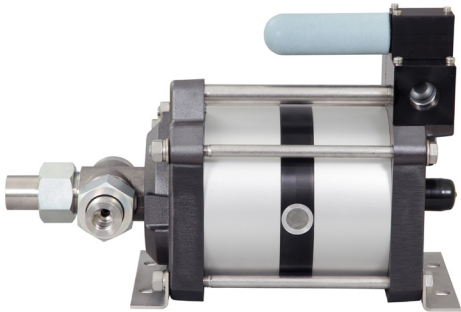

Double Air Drive Head

CATALOG NUMBER	A	AS	B	C	D	E	F
L10-2-VE L15-2-VE	16.12	13.63	12.13	3.88	10.81	11.81	4.38
L25-2-VE L35-2-VE	15.50	13.75	12.13	3.63	10.81	11.81	3.19
L60-2-VE	16.00	14.06	12.38	3.44	10.81	11.81	3.81
L100-2-VE L150-2-VE	15.50	14.00	12.25	4.00	10.81	11.81	3.81
L250-2-VE L300-2-VE L400-2-VE	19.63	18.13	16.25	2.75	10.81	11.75	3.38

NOTE: ¹ Mounting hole dimensions.
Dimension are subject to change. Consult factory.

L10-VE THROUGH L400-VE AND L10-2-VE THROUGH L150-2-VE

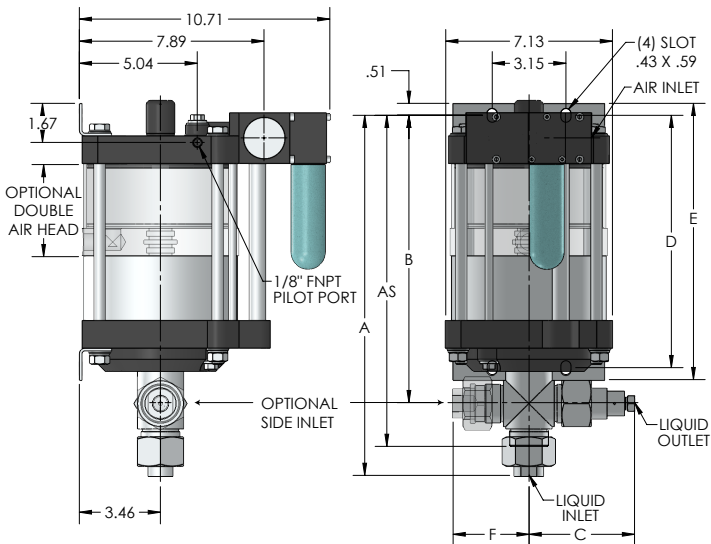

L500-S AND L250-2-VE THROUGH L500-2-S

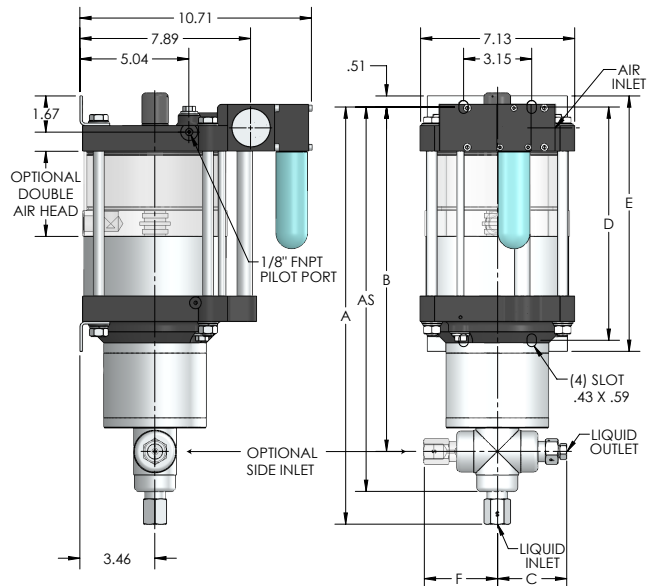

L-D

SERIES

PRESSURES FROM
165 TO 38,425 PSI

L-D pumps are double acting versions of the workhorse L series pumps.

- L-D pumps deliver approximately 50% more flow with less pulsation.
- All are single air head style, 8 pressure ratios available.
- Stainless steel bodies and plunger with UHMWPE (Ultra High Molecular Weight Polyethylene) seals and Viton² O-rings (-VE).
- L10D-L35D pumps are standard with bottom inlet. For a side inlet, add -S.
- L60-DS - L250DS pumps are only available with side inlet.
- Operating pressure range is 15-145 psi.
- For air control option, add -ACP to the catalog number.
- All L-D pumps come with an unregulated pilot port, 1/8" FNPT. This standard feature allows easy on/off pump control with a very small valve or pilot port.

TECHNICAL DATA

CATALOG NUMBER	PRESSURE RATIO	MAXIMUM OUTLET PRESSURE (PSI)	DISPL. PER CYCLE (IN. ³)	CONNECTIONS FNPT (IN.)		WEIGHT (LBS.)
				INLET (2)	OUTLET (2)	
L10D-VE	1:10	1,450	10.98	1	½	48
L15D-VE	1:15	2,175	7.56	1	½	
L25D-VE	1:27	3,915	4.31	½	½	42
L35D-VE	1:40	5,800	2.99	½	½	
L60DS-VE	1:63	9,135	1.92	½	½	37
L100DS-VE	1:113	15,225	1.07	½	½	
L150DS-VE	1:151	21,025	0.81	½	¼ HP	
L250DS-VE	1:265	38,425	0.46	½	¼ HP	

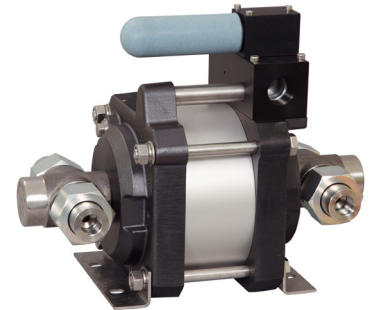

NOTE: Air drive inlet connection on all L-D pumps is 1/2" FNPT.
Air pilot connection is 1/8" and is required for operation.
Maximum allowable liquid temperature is 140°F.
Air section temperature rating: 0°F to 140°F.
Consult factory for L-D pump dimensions.
²Viton is a registered trademark of E.I DuPont de Nemours & Co., Inc.

FLOW CHART - L-D SERIES

CATALOG NUMBER	SAMPLE AIR DRIVE PRESSURE (PSI)	OUTLET PRESSURE (PSI)										
		0	500	1000	1500	2000	3000	4000	5000	7500	10000	15000
L10D-VE	60	1700	650									
	90	1750	1200									
L15D-VE	60	1150	775									
	90	1200	1000	550								
L25D-VE	60	660	580	385	120							
	90	680	630	540	220	220						
L35D-VE	60	460	420	350	250	140						
	90	460	450	415	370	300	140					
L60DS-VE	60	300	285	260	230	190	100					
	90	300	290	285	270	250	200	135				
L100DS-VE	60	165	162	155	150	140	120	97	65			
	90	165	163	161	160	157	134	132	120	69		
L150DS-VE	60	125	123	120	116	113	103	90	77	32		
	90	125	124	123	122	121	117	110	103	76	50	
L250DS-VE	60	70	69	68	67	66	63	62	60	50	38	7
	90	72	71	70	69	68	67	66	66	62	56	38

FLOW RATE IN CUBIC INCHES PER MINUTE.
MAXIMUM AIR CONSUMPTION: 45 SCFM @ 90 PSI (WITH 0 PSI OUTLET).

FLOW RATES SHOWN ARE FOR 1-10 CST FLUIDS.

WATER OR OIL SERVICE

GX

SERIES

PRESSURES FROM
540 TO 22,500 PSI

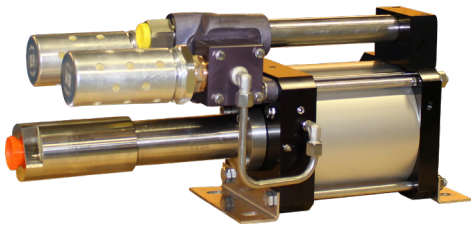

GX pumps are high-flow pumps designed for rugged installations and built with environmental resistant materials. They are ideal for offshore applications with stainless steel wetted parts and corrosive resistant external components.

- GX series pumps have stainless steel bodies and plunger with UHMWPE (Ultra High Molecular Weight Polyethylene) seals and Viton[®] O-rings.
- Inlet is in end of head and outlet is on side of head.
- Operating pressure range is 15 - 145 psi.
- For air control option, add -ACG to the catalog number.
- All GX pumps come with a pre-plumbed pilot port.

TECHNICAL DATA

CATALOG NUMBER	PRESSURE RATIO	MAXIMUM OUTLET PRESSURE (PSI)	DISPL. PER CYCLE (IN. ³)	CONNECTIONS (FNPT -IN.)		WEIGHT (LBS.)
				INLET	OUTLET	
GX35	1:36	5,220	6.71	1	3/8	53
GX60	1:66	8,700	3.97	1	3/8	
GX100	1:117	14,500	2.20	1	3/8	
GX170	1:177	22,500	2.20	1	3/8 MP	66

NOTE: All connections listed are FNPT unless otherwise noted
Air drive inlet connection on all GX pumps is 3/4" FNPT.
Maximum allowable liquid temperature is 140°F.
Air section temperature rating: 0°F to 140°F.
[®]Viton is a registered trademark of E.I DuPont de Nemours & Co., Inc.

DIMENSIONS (inches)

CATALOG NUMBER	GX35 GX60 GX100	GX170
A	22.67	24.50
B	10.59	10.83
C	3.50	4.33
D	4.33	5.51
E	9.69	10.79
F	9.44	9.80

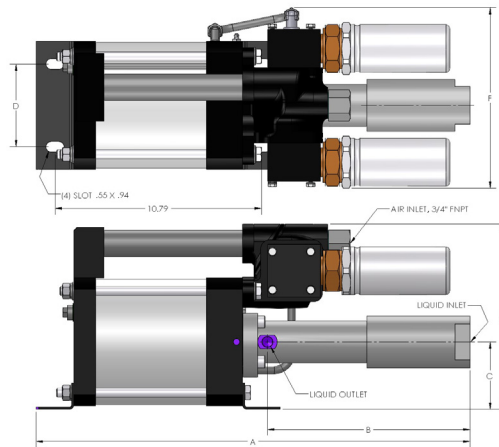

FLOW CHART - GX SERIES

CATALOG NUMBER	SAMPLE AIR DRIVE PRESSURE (PSI)	OUTLET PRESSURE (PSI)										
		0	500	1000	2000	3000	4000	5000	7500	10000	15000	
GX35	60	1525	1400	1100	180							
	90	1525	1450	1360	635	150						
GX60	60	850	820	750	570	310						
	90	850	840	815	720	590	420	180				
GX100	60	470	465	460	410	360	280	210				
	90	470	465	460	455	430	390	350	220			
GX170	60	335	329	323	314	287	261	232	153	18		
	90	335	332	330	329	319	308	293	254	183	30	

FLOW RATE IN CUBIC INCHES PER MINUTE.
MAXIMUM AIR CONSUMPTION: 190 SCFM @ 90 PSI (WITH 0 PSI OUTLET).

FLOW RATES SHOWN ARE FOR 1-10 CST FLUIDS.

WATER OR OIL SERVICE

GPD pumps are high-flow pumps designed for rugged installations and built with environmental resistant materials. They are ideal for offshore applications with stainless steel wetted parts and corrosive resistant external components.

- **GPD series pumps have stainless steel bodies and plungers, UHMWPE (Ultra High Molecular Weight Polyethylene) seals and Viton[®] O-rings.**
- **Double acting design for high flow rate**
- **Separation sleeves to prevent contamination of the air drive.**

GPD

SERIES

**PRESSURES FROM
450 TO 43,500 PSI**

TECHNICAL DATA

GPD Single Air Drive Head

CATALOG NUMBER	PRESSURE RATIO	MAXIMUM OUTLET PRESSURE (PSI)	DISPL. PER CYCLE (IN ³)	CONNECTIONS (FNPT -IN.)		WEIGHT (LBS)
				INLET (2)	OUTLET (2)	
GPD30	1:30	4350	31	3/4	3/4	128
GPD60	1:60	8700	15.7	3/4	3/4	
GPD120	1:129	17400	7.4	3/4	13/16-16 (9MF)	
GPD180	1:192	27840	4.2	1/4	3/4-16 (6HF)	
GPD260	1:277	40165	2.9	1/4	3/4-16 (6HF)	
GPD Double Air Drive Head						
GPD30-2	1:60	8700	31	3/4	3/4	172
GPD60-2	1:120	17400	15.7	3/4	13/16-16 (9MF)	
GPD120-2	1:258	37400	7.4	3/4	3/4-16 (6HF)	
GPD180-2	1:384	43500	4.2	1/4	3/4-16 (6HF)	
GPD260-2	1:554	43500	2.9	1/4	3/4-16 (6HF)	

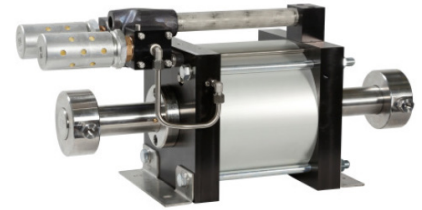

NOTE: All connections listed are FNPT unless otherwise noted.
Air drive inlet connection on all **GPD pumps is 3/4" FNPT.**
Maximum allowable liquid temperature is 140°F.
Air section temperature rating: 0°F to 140°F.
[®]Viton is a registered trademark of E.I DuPont de Nemours & Co., Inc.

FLOW CHART - GPD SERIES

CATALOG NUMBER	SAMPLE AIR DRIVE PRESSURE (PSI)	OUTLET PRESSURE (PSI)										
		0	500	1500	3000	5000	7500	10000	15000	20000	30000	40000
GPD30	60	2550	1750	375								
	80	2775	2050	900								
GPD60	60	1125	950	600	175							
	80	1200	1025	750	375							
GPD120	60	590	560	440	310	160	10					
	80	630	600	500	400	260	120					
GPD180	60	395	390	360	255	190	105	25				
	80	425	420	390	300	250	180	110				
GPD260	60	255	250	240	200	165	125	90	20			
	80	275	270	260	220	200	165	135	75	20		
GPD30-2	60	1375	1150	750	225							
	80	1450	1250	925	500							
GPD60-2	60	690	640	520	370	200						
	80	740	700	600	470	320	140					
GPD120-2	60	330	320	300	250	210	150	100	10			
	80	350	355	330	280	250	200	160	80	10		
GPD180-2	60	235	225	210	190	165	135	105	55	10		
	80	250	245	235	215	195	175	150	115	80	10	
GPD260-2	60	150	150	145	135	125	105	95	75	55	10	
	80	160	160	155	150	140	130	120	100	85	50	20

FLOW RATE IN CUBIC INCHES PER MINUTE.
MAXIMUM AIR CONSUMPTION: 190 SCFM @ 90 PSI (WITH 0 PSI OUTLET).

FLOW RATES SHOWN ARE FOR 1-10 CST FLUIDS.

CHEMICAL SERVICE

PPSF

SERIES

PRESSURES FROM
60 TO 14,500 PSI

PPSF pumps are rugged and designed for chemical service applications. These pumps are available as single acting pumps with single air drive head and distance piece which provides a separation between the liquid and air drive sections.

- PPSF pumps have stainless steel pump heads and plungers.
- PPSF pumps have PTFE seals with Viton² O-rings.
- PPSF pumps are standard with bottom inlet. For a side inlet, add -S to the catalog number.
- Maximum air drive pressure is 145 psi. PPSF pumps require less drive pressure because the pump is driven in both directions with no spring under the piston. This design reduces noise and provides less chance of cavitation.
- Minimum air drive pressure 15 psi.
- For air control option, add -ACM to the catalog number.

TECHNICAL DATA

PPSF Single Air Drive Head and Distance Piece

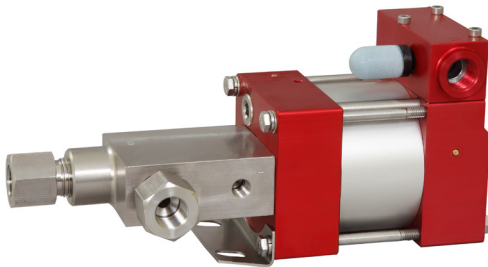

CATALOG NUMBER	PRESSURE RATIO	MAXIMUM OUTLET PRESSURE (PSI)	DISPL. PER CYCLE (IN. ³)	CONNECTIONS (FNPT - IN.)		WEIGHT (LBS.)
				INLET	OUTLET	
PPSF4	1:4	580	1.86	1	½	15
PPSF8	1:9	1,305	0.90	¾	½	
PPSF12	1:14	2,030	0.57	3/8	¼	
PPSF22	1:28	4,060	0.28	3/8	¼	8
PPSF37	1:46	6,670	0.17	3/8	¼	
PPSF72	1:86	12,470	0.09	3/8	¼	
PPSF111	1:130	14,500	0.06	3/8	¼	

NOTE: Air drive inlet connection on all PPSF pumps is 1/4" FNPT.
All connections listed are FNPT unless otherwise noted.
Maximum allowable liquid temperature is 248°F.
Air section temperature rating: 0°F to 140°F.

FLOW CHART - PPSF Series

CATALOG NUMBER	SAMPLE AIR DRIVE PRESSURE (PSI)	OUTLET PRESSURE (PSI)							
		0	500	1500	3000	5000	7500	10000	14500
PPSF4	60	885							
	90	905							
PPSF8	60	422	50						
	90	430	240						
PPSF12	60	272	160						
	90	275	218						
PPSF22	60	132	110	22					
	90	136	126	82					
PPSF37	60	81	74	47					
	90	83	80	68	37				
PPSF72	60	43	42	37	22	3			
	90	44	43	41	36	24	3		
PPSF111	60	28	27	26	20	12	2		
	90	29	28	27	26	22	16	8	

FLOW RATE IN CUBIC INCHES PER MINUTE.

MAXIMUM AIR CONSUMPTION: 20 SCFM @ 90 PSI (WITH 0 PSI OUTLET).

FLOW RATES SHOWN ARE FOR 1-10 CST FLUIDS.

CHEMICAL SERVICE

LSF series pumps are rugged and designed for chemical service applications. These pumps are available as single acting pumps with single or double air drive head and distance piece which provides a separation between the liquid and air drive sections.

- LSF pumps have stainless steel pump heads and plungers.
- LSF pumps have PTFE seals with Viton² O-rings.
- Pumps are standard with bottom inlet. For a side inlet, add -S.
- Maximum air drive pressure is 145 psi.
- Minimum air drive pressure 15 psi.
- For air control option, add -ACP to LSF catalog number.

LSF

SERIES

**PRESSURES FROM
165 TO 23,200 PSI**

TECHNICAL DATA

LSF Single Air Drive Head and Distance Piece

CATALOG NUMBER	PRESSURE RATIO	MAXIMUM OUTLET PRESSURE (PSI)	DISPL. PER CYCLE (IN. ³)	CONNECTIONS (FNPT - IN.)		WEIGHT (LBS.)
				INLET	OUTLET	
LSF10	1:11	1,595	5.49	1	½	44
LSF15	1:16	2,320	3.78	1	½	
LSF25	1:28	4,060	2.15	½	½	42
LSF35	1:40	5,800	1.49	½	½	
LSF60	1:63	9,135	0.94	½	½	40
LSF100	1:113	15,225	0.54	½	½	
LSF150	1:151	21,025	0.40	½	¼ HP	
LSF250	1:265	23,200	0.23	½	¼ HP	



NOTE: Air drive inlet connection on all LSF pumps is 1/2" FNPT.
Air pilot connection on all LSF pumps is 1/8" FNPT.
All connections listed are FNPT unless otherwise noted.
Maximum allowable liquid temperature is 248°F.
Air section temperature rating: 0°F to 140°F.
²Viton is a registered trademark of E.I. DuPont de Nemours & Co., Inc.

LSF Double Air Drive Head and Distance Piece

LSF10-2	1:22	3,190	5.49	1	½	50
LSF15-2	1:32	4,640	3.78	1	½	
LSF25-2	1:56	8,120	2.15	½	½	
LSF35-2	1:80	11,600	1.49	½	½	
LSF60-2	1:126	15,000	0.94	½	½	
LSF100-2	1:226	23,200	0.54	½	¼ HP	

FLOW CHART - LSF Series

CATALOG NUMBER	SAMPLE AIR DRIVE PRESSURE (PSI)	OUTLET PRESSURE (PSI)							
		0	500	1500	3000	5000	7500	10000	15000
LSF10	60	1100	350						
	90	1125	790						
LSF15	60	775	540						
	90	790	650						
LSF25	60	435	365	60					
	90	445	410	265					
LSF35	60	300	270	150					
	90	305	290	240	95				
LSF60	60	192	182	145	45				
	90	195	190	173	130	43			
LSF100	60	108	105	97	78	37			
	90	110	108	105	95	78	47	5	
LSF150	60	81	79	76	66	49	19		
	90	83	82	80	75	67	53	35	
LSF250	60	46	45	44	42	37	26	20	2
	90	47	46	45	44	43	40	36	26
LSF10-2	60	880	720						
	90	890	800	350					
LSF15-2	60	615	550	200					
	90	625	575	410					
LSF25-2	60	345	330	265	60				
	90	350	335	300	208	15			
LSF35-2	60	240	230	210	115				
	90	242	232	225	190	115			
LSF60-2	60	150	148	145	120	70	2		
	90	155	152	147	136	117	80	33	
LSF100-2	60	86	84	82	77	72	53	30	
	90	87	86	8	82	78	70	61	36

PORTABLE SYSTEMS

POWER PACKS

Portable systems are ideal for generating elevated hydraulic or water pressures, using only shop air, at a variety of locations throughout a facility. They are completely portable and require only a shop air line to operate if the reservoir option is selected.

A variety of pressure ranges are available to fit your specific requirements, from low pressures of 1,000 psi to high pressures of 101,000 psi. You may choose from a number of options to complete the test system best suited for your application.



Power Packs - OIL OR WATER

- ◆ Lightweight, portable
- ◆ Economical hydraulic power
- ◆ Totally self-contained package

ORDERING INFORMATION*

	MTPP	03	-	O	-	PPO	-	1G	-	G
	Max. Req'd Pressure		Service		Pump		Reservoir		Options	
01	1,000 psi	O	Oil	PPO or S	Oil	N	None, plate mounted	G	Outlet gauge	
02	2,000 psi	W	Water	PP or L	Water			V	Vent valve	
03	3,000 psi					1G	1 gallon S.S.	RD	Relief Device	
05	5,000 psi					2G	2 gallon S.S.		Call to discuss your specific application.	
10	10,000 psi					8G	8 gallon S.S.			
60	60,000 psi					1.5G	1.5 gallon carbon steel			

TEST CARTS

Test Carts - OIL OR WATER

- ◆ Hydrostatic testing
- ◆ Hydraulic power
- ◆ Cycle testing
- ◆ Leak testing

ORDERING INFORMATION*

	MTTC	10	-	O	-	L	-	8GP	-	RD
	Max. Req'd Pressure		Service		Pump		Reservoir		Options	
01	1,000 psi	O	Oil	PPO or S	Oil	N	None	ACC	Outlet gauge	
03	3,000 psi	W	Water	PP, L or	Water	2G	2 gallon S.S.	DG	Vent valve	
05	5,000 psi			GX		8G	8 gallon polyethylene	DV	Relief Device	
10	10,000 psi					8GSS	8 gallon S.S.	RD		
60	60,000 psi									



POWER CUBE

Power Cube Hydrostatic Test Unit - MODEL #MTPC30-W-L60-L250-N-RD

The MAXPRO Power Cube is designed for quick, convenient, and accurate hydrostatic testing. It features large dual pumps, a no-nonsense control panel, and high flow in a rugged stainless compact design with an economical price. You just need to provide a compressed air supply and water.



MT PC Maxpro Technologies Power Cube

30 = 30,000 psi

W = Water

L60 = L60 Pump

L250 = L250 Pump

N = No Reservoir

RD = Relief Device

PUMP SKIDS



Pump Skids - OIL OR WATER

- ◆ Compact, complete packaged systems
- ◆ Standard powder coated or stainless steel frame

Pump skids are compact systems with most components mounted within the boundaries of the frame. The systems can be built for water or oil service and have a control panel to contain all gauges and valves.

A variety of pressure ranges and flows are available, for testing components, ranging from 500 psi to 60,000 psi. These systems can be supplied with a reservoir or a city water valved inlet. Reservoirs come with a fill/breather cap, liquid level sight gauge and drain connection.

ORDERING INFORMATION*

	MTPS	05	-	W	-	PP72	-	2G	-	RD
	Max. Req'd Pressure		Service		Pump		Reservoir		Options	
01	1,000 psi	O	Oil	PPO or S	Oil	N	None, plate mounted	G	Outlet gauge	
02	2,000 psi	W	Water	PP or L	Water			V	Vent valve	
03	3,000 psi						1G	1 gallon S.S.	RD	Relief Device
05	5,000 psi						2G	2 gallon S.S.		Call to discuss
10	10,000 psi						8G	8 gallon S.S.		your specific application.
60	60,000 psi						1.5G	1.5 gallon carbon steel		

TEST BENCHES



Test Benches - OIL OR WATER, AIR OR GAS

- ◆ Hydrostatic testing
- ◆ Burst testing
- ◆ Cycle/fatigue testing
- ◆ Leak testing

MAXPRO test benches are designed for durability, ease of use and accessibility. These test benches can be equipped for use with oil, water, air, gas or any combination of test medium. The same test bench could be set up for hydrostatic testing with water and/or leak testing with gas.

MAXPRO test benches can be provided with manual control or push button PLC control to handle your specific application.

Test chambers can be included and can be horizontal or vertical. When specifying a test bench that is to include a test chamber with a windowed door, please specify the required chamber size.

ORDERING INFORMATION*

	MTTB	10	-	W	-	G	-	M	-	L	-	N	-	DLE	-	RS	-	
	Pressure		Service		Operation		Air Amplifier		Pump		Options							
05	1,000 psi	O	Oil	M	Manual		GPLV2	2:1 amplifier	L	Water Pumps	RI	Remote operating isolation valve						
10	2,000 psi	W	Water	R	Push Button		DLA	5:1 and 15:1 amplifier	N	None	RS	Remote operating pump shut-off valve						
15	3,000 psi	A	Air to 5,000 psi maximum				N	None			RV	Remote operating vent valve						
20	5,000 psi	G	Gas to 21,000 psi maximum								T	Pressure transducer specify 0-10V or 4-20 ma output						
30	10,000 psi	N	None - for second service								DP	Digital pressure indicator						
60	60,000 psi										PI	Peak pressure indicator						



* The photos and ordering information are shown to indicate capabilities and options. Each system is custom designed to meet specific operating requirements.

ACCESSORIES

HIGH PRESSURE RELIEF VALVES

MT3RV

PRESSURES FROM 500 TO 3,000 PSI

MT10RV

PRESSURES FROM 1,000 TO 10,000 PSI

MT25RV

PRESSURES FROM 2,500 TO 25,000 PSI

MT66RV

PRESSURES FROM 10,000 TO 66,000 PSI



Catalog Number	Connection Size		Orifice (in.)	Service	Pressure Rating (psi) @ R.T.		Valve Panel Hole	Body Diameter
	Inlet	Outlet			Minimum Setting	Maximum Setting		
MT3RV	1/4" FNPT (2)	1/4" FNPT	0.070	Liquid/Gas	500	3,000	1.38	1.50
MT10RV	1/4" FNPT (2)	1/4" FNPT	0.070	Liquid/Gas	1,000	10,000	1.38	1.50
MT25RV	1/4" HP	1/4" FNPT	0.070	Liquid/Gas	2,500	25,000	1.625	2.00
MT66RV	1/4" UHP	1/4" FNPT	0.070	Liquid/Gas*	10,000	66,000	1.625	2.00

* Not bubble tight on gas service

All general terms and conditions of sale, including limitations of our liability, apply to all products and services sold.

DRY AIR SPOOLS For severe duty service

In applications where very dry air or nitrogen is used to drive Maximator pumps or boosters, there is a spool seal option available to provide longer duty between maintenance. This Dry Air Spool (DAS) option should be considered for extreme operating conditions involving air or gas drive mediums below 0°F. dewpoint, and similarly, very cold climate applications (-40°C.) This design can be retrofitted to existing pumps and boosters as it only involves the spool, spool sleeve, and seals. The spool block remains the same. Be sure to use an appropriate tool to pull the spool sleeve! Minimum air drive with this option is 30 psig. To order with a pump simply add - DAS to model number. To retrofit to an existing pump, order "Dry Air Spool" and specify the pump model and serial number.



AIR CONTROL PACKAGES

Consisting of a filter, regulator with gauge, shut-off valve and required fittings

- ACM....For all PPO, PP & PPSF pumps, and MPLV air amplifiers
- AC.....For all S Pumps
- ACP....For all L & LSF pumps, DLA & GPLV air amplifiers and DLE gas boosters
- ACG....For all GX pumps



PUMP CYCLE COUNTERS

To order: add suffix to pump P/N, eg. PPO12-CCW
CCP...Panel mount, 0 - 999,999 max. cycles, 1" high x 2" wide hole
CCW...Wall mount, 0 - 999,999 max cycles
 Reset button on both models
 Direct pump mounting is available



MAXPRO DATA LOGGER/PUMP CONTROLLER

Maxpro Technologies introduces a pump control feature for our Data Logger to provide a quick and easy way to control pump operation. The unit is designed to digitally record pressure during tests, complementing Maxpro pump and booster packaged power systems. Pressure loggers are useful in any industry that needs an easy, accurate way to record pressure tests. Options for multiple channels, temperature flow and other data are available. It is also programmable to provide basic pump operation control.

The standard Pressure Logger comes with a pressure transducer, two preformatted jump drives, and instructions including step-by-step instructions on how to create customized test reports on your computer.

New: Optional rechargeable battery to allow total independent on-site use and power back up

PRESSURE LOGGER FEATURES	PUMP CONTROLLER FEATURES
7" Color Touch Screen	Programmable Air Driven Pump Control
Instant Test Report <ul style="list-style-type: none"> • Customizable • Trend Pan & Zoom • Trend Watchline USB 2.0 Port Ethernet Port AC Power: 115/230 V 50/60 Hz Digital Indication of Realtime & Peak Pressure Live On-Screen Trending with Watchline Data Storage for input into spreadsheet Auto Peak Reset Pressure ranges from 0-500 psi to 0-100,000 psi available Network Print Server Software available Dimensions: 10" H x 18" W x 8" D, 15#	Virtually Unlimited Number of Recipes Specifying: <ul style="list-style-type: none"> • Pump Ratio • Up to Five Steps/Ramps of Pressure Rise • Maximum Pressure Not to Exceed • Setpoint Program <ul style="list-style-type: none"> * Hold Pressure * Stabilization Time * Hold Time * Hold Mode * Maintain Pressure/Allow Decay Pneumatic Specifications: <ul style="list-style-type: none"> • Air Input: 145 PSI Maximum • Air Output: 0-130 PSI @ 140 SCFM Max • Connection: 1/2" NPT • Inlet Filtration: 40 Microns

AVAILABLE OPTIONS: Keyboard with Touchpad, Rechargeable Battery Pack (120 VAC operation remains primary), Thermocouple with RTD Temperature Sensors, Multiple Sensors for different pressure ranges.



OTHER PRODUCTS

Valves, Fittings & Tubing

- Highest quality for superior product performance
- Standard material high strength stainless steel
- Pressures to 152,000 PSI

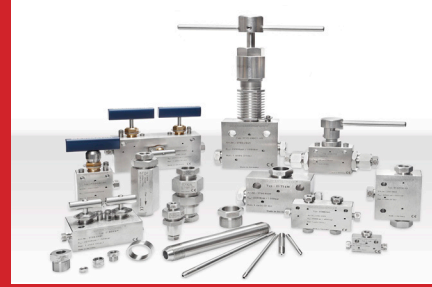

Air Amplifiers & Systems

- Air driven to 4,350 PSI
- Deliver increased air pressure to shop floor equipment and work stations
- Require no electrical power
- Single or double acting models



Gas Boosters & Systems

- Air driven to 36,000 PSI
- Ideal for gas salvage
- Units are contaminant free
- For use with a variety of gases
- Require no lubrication or electrical power



Repair Service Available

- Guaranteed quality workmanship
- Cost effective quick turnaround
- Use original manufacturer parts
- Factory support

MAXIMATOR® US
MAXPRO Technologies

7728 Klier Drive South • Fairview, PA 16415
Phone: 814-474-9191 • Fax: 814-474-9391
Web Site: www.maxprotech.com
E-mail: sales@maxprotech.com

All technical and dimensional information subject to change.

All general terms and conditions of sale, including limitations of our liability, apply to all products and services sold.